

(19) World Intellectual Property Organization  
International Bureau



(43) International Publication Date  
7 October 2010 (07.10.2010)

(10) International Publication Number  
**WO 2010/114660 A1**

(51) International Patent Classification:  
*C25B 9/10* (2006.01)     *A61M 5/142* (2006.01)  
*A01M 1/20* (2006.01)     *F16N 13/00* (2006.01)  
*A61L 9/12* (2006.01)

(74) Agent: **STEINS, Karl, M.**; Steins & Associates, P.C.,  
2333 Camino Del Rio South, Suite 120, San Diego, CA  
92108 (US).

(21) International Application Number:  
PCT/US2010/025852

(81) Designated States (unless otherwise indicated, for every kind of national protection available): AE, AG, AL, AM, AO, AT, AU, AZ, BA, BB, BG, BH, BR, BW, BY, BZ, CA, CH, CL, CN, CO, CR, CU, CZ, DE, DK, DM, DO, DZ, EC, EE, EG, ES, FI, GB, GD, GE, GH, GM, GT, HN, HR, HU, ID, IL, IN, IS, JP, KE, KG, KM, KN, KP, KR, KZ, LA, LC, LK, LR, LS, LT, LU, LY, MA, MD, ME, MG, MK, MN, MW, MX, MY, MZ, NA, NG, NI, NO, NZ, OM, PE, PG, PH, PL, PT, RO, RS, RU, SC, SD, SE, SG, SK, SL, SM, ST, SV, SY, TH, TJ, TM, TN, TR, TT, TZ, UA, UG, US, UZ, VC, VN, ZA, ZM, ZW.

(22) International Filing Date:  
2 March 2010 (02.03.2010)

(25) Filing Language: English

(26) Publication Language: English

(30) Priority Data:  
12/413,546     28 March 2009 (28.03.2009)     US

(71) Applicant (for all designated States except US): **M&R CONSULTING SERVICES, INC.** [US/US]; 10633 Roselle Street, Suite E, San Diego, CA 92121 (US).

(84) Designated States (unless otherwise indicated, for every kind of regional protection available): ARIPO (BW, GH, GM, KE, LS, MW, MZ, NA, SD, SL, SZ, TZ, UG, ZM, ZW), Eurasian (AM, AZ, BY, KG, KZ, MD, RU, TJ, TM), European (AT, BE, BG, CH, CY, CZ, DE, DK, EE, ES, FI, FR, GB, GR, HR, HU, IE, IS, IT, LT, LU, LV,

(72) Inventor: **MAGET, Henri, J. R.**; 10633 Roselle Street, Suite E, San Diego, CA 92121 (US).

[Continued on next page]

(54) Title: ELECTROCHEMICAL GAS GENERATOR AND CELL ASSEMBLY

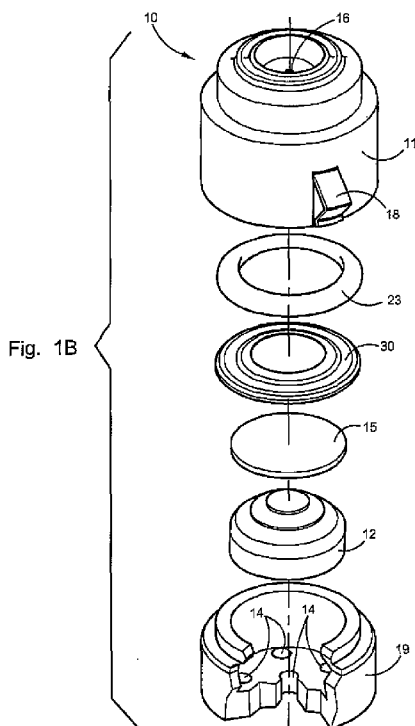

(57) Abstract: Small, autonomous, low cost electrochemical gas generators containing an electrochemical cell assembly, a commercially available battery and a current controlling mechanism. Current control, which defines the gas generation rate, is achieved either electronically by means of a resistor or through mass transfer control by means of a gas permeable film of known permeability. In either case, the gas generation rates are generally from 0.1 to 10 cc/day. The gas source must contain an electrochemically active gas such as oxygen or hydrogen. Air is the preferred source for oxygen. These miniature gas generators, generally are less than 1.5 cm in diameter and length, require novel, compact, electrochemical cell assemblies. Various cell assemblies, generally 1 cm in diameter and less than 05 mm thick, are described. These miniature gas generators are used for the controlled release of fluids such as pheromones, fragrances, insect repellents, and me like.

WO 2010/114660 A1

MC, MK, MT, NL, NO, PL, PT, RO, SE, SI, SK, SM, **Published:**  
TR), OAPI (BF, BJ, CF, CG, CI, CM, GA, GN, GQ, GW,  
ML, MR, NE, SN, TD, TG).

- with international search report (Art. 21(3))
- with amended claims (Art. 19(1))

**Declarations under Rule 4.17:**

- as to the identity of the inventor (Rule 4.17(i))
- as to applicant's entitlement to apply for and be granted a patent (Rule 4.17(ii))

TITLE

**ELECTROCHEMICAL GAS GENERATOR AND CELL ASSEMBLY**

CROSS REFERENCES TO RELATED APPLICATIONS

None.

STATEMENT REGARDING FEDERALLY-SPONSORED RESEARCH OR  
DEVELOPMENT

Not applicable.

BACKGROUND

Typical miniature gas sources generate gases at rates from about 0.05 to 100 cc/day and are used for a variety of purposes. A primary use of the gas source is to produce mechanical work, such as may be required for delivering fluids at low flow rates. Many

miniature gas sources use chemical means to generate the gases; but these are often unreliable, resulting in time-dependent generation rates.

Another source for generating gases involves the use of an electrochemical means. Electrochemical means to generate gases generally are more accurate, reliable, albeit they require a power source, generally in the form of commercial batteries.

Types of gases generated electrochemically typically include hydrogen, oxygen, and carbon dioxide. In some instances, as described by Winsel in U.S. Patent Number 5,242,565, the battery is the power source as well as being the hydrogen gas generator. Other examples of electrochemical oxygen generators have been described by Maget in U.S. Patent Number 6,010,317. Their applications to fluid delivery have also been described by Maget in U.S. Patent Numbers 4,687,423; 4,886,514; 4,902,278; 5,928,194; 5,938,640; 5,971,722; 6,383,165, and 6,413,238.

Additional examples of electrochemical generators releasing carbon dioxide and hydrogen have been described by Swanson, et. al., in U.S. Patent Number 7,316,857 and by Maget in U.S. Patent Number 6,780,304. Setting the gas generation rates of electrochemical generators, however, requires conventional current controllers.

For commercial commodity products, such as releasers of pheromones, fragrances, insecticides, etc., a low cost for the gas generator is of paramount importance. The purpose of the present invention is to describe miniature and autonomous oxygen-gas generators that are cost-compatible with commercial commodity products, and in some instances are low cost gas sources that do not, but could, require electronic controls.

### SUMMARY

The above-noted problems, among others, are overcome by the electrochemical gas generator. Briefly stated, the electrochemical gas generator has a unique electrochemical cell assembly generating gases either through a controlled electric current [current-based] or through an oxygen-permeable film of a known permeability [film-based] placed at or near to the top of the electrochemical gas generator or the bottom of the electrochemical gas generator. The preferred gas to be generated is oxygen, though other gases may also be generated as necessary. The electrochemical cell assembly generates gases either through controlled electric current [current-based] or through an oxygen-permeable film of a known permeability [film-based]. Each type of cell assembly has an electrolytic membrane and a catalytically active electrode above and below the electrolytic membrane.

In the current-based type, a conductive and porous current collector is above each electrode and an upper and a lower oxygen-impermeable film encircles and presses onto each current collector thereby forming an air-tight seal therearound. Gases are generated and released based on the current flow when the electrochemical gas generator is activated.

In the film-based type, a conductive and porous current collector is above the upper electrode and an oxygen-permeable film of the conductive type of a pre-determined oxygen permeability is below the lower electrode, and an upper and a lower oxygen-impermeable film encircles and presses onto the upper current collector and onto the oxygen-permeable film thereby forming an air-tight seal therearound. Gases are generated and released based on the oxygen-permeability when the electrochemical gas generator is activated.

The gas generators of this disclosure are small, autonomous, low cost electrochemical gas generators containing, as described above, an electrochemical cell assembly, a commercially available battery, and a current controlling mechanism which defines the gas generation rate and is achieved either electronically by means of a resistor or through mass transfer control by means of a gas permeable film of known permeability. In either case, the gas generation rates are generally from 0.1 to 10 cc/day. The gas source must contain an electrochemically active gas such as oxygen or hydrogen. Air is the preferred source for oxygen. These miniature gas generators, generally are less than 1.5 cm in diameter and length, require novel, compact, electrochemical cell assemblies. Various cell assemblies, generally 1 cm in diameter and less than 05 mm thick, are described. These miniature gas generators are used for the controlled release of fluids such as pheromones, fragrances, insect repellents, and the like.

The foregoing has outlined the more pertinent and important features of the electrochemical gas generator in order that the detailed description that follows may be better understood so the present contributions to the art may be more fully appreciated. Additional features of the electrochemical gas generator will be described hereinafter which form the subject of the claims. It should be appreciated by those skilled in the art that the conception and the disclosed specific embodiment may be readily utilized as a basis for modifying or designing other structures and methods for carrying out the same purposes of the electrochemical gas generator. It also should be realized by those skilled in the art that such equivalent constructions and methods do not depart from the spirit and scope of the electrochemical gas generator as set forth in the appended claims.

### BRIEF DESCRIPTION OF THE DRAWINGS

For a fuller understanding of the nature and objects of the electrochemical gas generator, reference should be had to the following detailed description taken in conjunction with the accompanying drawings in which:

Figure 1A is a cross-section view of one embodiment of the electrochemical gas generator.

Figure 1B is an exploded view of the electrochemical gas generator illustrated in Figure 1A.

Figure 2A is a cross-section view of another embodiment of the electrochemical gas generator.

Figure 2B is an exploded view of the electrochemical gas generator illustrated in Figure 2A.

Figure 3A is a cross-section detailed view of one embodiment of an electrochemical cell assembly which may be film-controlled or current-controlled.

Figure 3B is a cross-section detailed view of another embodiment of an electrochemical cell assembly which is film-controlled.

Figure 4A is a cross-section view of another embodiment of the electrochemical gas generator which is film-controller using conductive film.

Figure 4B is an exploded view of the electrochemical gas generator illustrated in Figure 4A.

### DETAILED DESCRIPTION

Figures 1A and 1B are representative of a preferred embodiment of the present miniature and autonomous electrochemical gas generator 10 the gas generation of which is controlled by the simplest form of current controller, a resistor 20 [the gas generated herein typically is oxygen]. It is small, compact, easy to manufacture and assemble, simple to use, efficient, and cost-effective. This particular electrochemical gas generator 10 is of the current-controlled resistor based type in that generation of gases is controlled by a commercial resistor. An important component of this electrochemical gas generator is the electrochemical cell assembly 30. This particular electrochemical cell assembly 30 is illustrated in detail in Figure 3A and a second embodiment is illustrated in detail in Figure 3B.

This electrochemical gas generator 10 comprises a container 11 made of conductive material. The container 11 has a chamber 13 therein to accept a battery housing 19, a battery 12, and the resistor 20 with a first contact point 21 in communication with the battery 12 at one end and a second contact point 22 in potential communication with the activation arm 18 at the other end. Activation of this electrochemical gas generator 10 occurs when it is placed into a suitable container having a diameter approximately equal to or slightly greater than the diameter of the electrochemical gas generator 10 which causes the activation arm 18 to move in the direction of Arrow A and thereby come into contact with the second contact point 22 causing the process to begin.

An inlet 14 [one or more for allowing entry of any oxygen-containing gas, such as, but not limited to, air] at the bottom of the container 11 permits the entry of air which will



flow around the battery 12 and up to the electrochemical cell assembly 30 where oxygen will be extracted and released through the outlet 16 on top of the container 11. Resting on top of the battery 12 in this embodiment is a conductive member 15 generally comprised either of, but not limited to, conductive rubber or a metal screen. The conductive member 15 ensures good electrical contact between the battery 12 and the electrochemical cell assembly 30.

Figure 3A illustrates in detail the electrochemical cell assembly 30 of this current-based current-controller generator 10. It is composed of a solid electrolytic membrane 31 onto which electrodes 32 are embedded. Current collectors 33 are on the top and bottom of the electrolytic membrane 31 and are in intimate contact with each electrode 32 to insure low resistance electrical contacts. This membrane-electrode/current-collector 31, 32, 33 combination is encircled by, and partially sandwiched between, an oxygen impermeable film 34 which is used to seal off the edges by way of outward extensions 35. As can be seen clearly in Figures 1A and 1B, the oxygen impermeable film 34 with the outward extensions 35, in conjunction with the sealing ring 23, will prevent air from circulating around the electrochemical cell assembly 30 but forces the air to flow to the electrochemical cell assembly 30 from its air intake side 24, to be processed, with oxygen being released at the discharge side 26 of the electrochemical cell assembly 30 and out of the electrochemical gas generator 10 through its outlet 16.

The top of the container 11 has a recess 17 which, when assembled with the electrochemical cell assembly 30 inside, presses on the electrochemical cell assembly 30. This maintains a tight fit of the electrochemical cell assembly 30 therein and on the conductive member 15 in tight communication with the top of the battery 12. An air-tight

seal is formed to prevent air from flowing around the electrochemical cell assembly 30 and to prevent the generated oxygen to reverse flow and escape to the air intake side 24 of the electrochemical cell assembly 30.

Reference is now made to Figure 1B for assembly of this current-based electrochemical gas generator 10. First the sealing ring 23 is placed into the inverted housing 11 followed by the electrochemical cell assembly 30, conductive member 15, battery holder 19 with battery 12 and resistor 20 therein. The bottom of the housing 11 is crimped inward and upward. Once so assembled and properly crimped, this electrochemical gas generator 10, when activated becomes operational.

Referring now to Figure 3A, typical conventionally available components of the electrochemical cell assembly 30 include:

[1] for the resistor [20], a Vishay low -power surface mount chip resistor;

[2] for the electrolytic member (cation or anion) [31], a typical membrane which is manufactured by DuPont® and known as Nafion® ;

[3] for the electrodes [32], catalytically active materials such as platinum black or platinum activated carbons or graphite;

[4] for the current collector [33], which typically should be approximately 320 microns thick and less than 5mm in diameter, porous conductive carbons or graphite paper or porous conductive materials such as conductive silicone rubber or a metal screen; and

[5] for the oxygen impermeable film [34] and outward extensions [35], DuPont's® commercially available Kapton® film which generally should be of the non-conductive type.

As illustrated in detail in Figure 3A, the oxygen impermeable film 34 and its outward extensions 35 sandwich the membrane-electrode, current-collector combination 31, 32, and 33 and, with the outward extensions 35, prevents air from circulating around the electrochemical cell assembly 30.

There is a substantially wide mouth opening on both the bottom surface and the top surface of the electrochemical cell assembly which defines a respective intake side 24 [bottom] and a discharge side 26 [top]. When the electrochemical cell assembly 30 is combined with the container assembly 11 described above, the air-tight seal described above forces air or any other oxygen-containing gas source to flow to the electrochemical cell assembly 30 from the intake side 24 of the electrochemical cell assembly 30 to be processed, with oxygen being released at the discharge side 26 of the electrochemical cell assembly 30 and out of the electrochemical gas generator 10 through its outlet 16.

Electrochemical oxygen enrichment using air as a source has been previously described in the prior art. The process is typically conducted by applying a voltage across an electrochemical cell consisting of catalytic anode and cathode and an electrolytic member or ionic polymer such as DuPont's Nafion®. Electrode processes are:

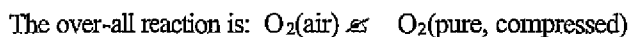
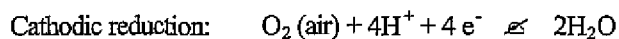

The correlation between current and gas generation rate, at 25°C is 5.5 cc of oxygen/day-mA. Conversely, the amount of energy required to generate 1 cc of oxygen is

4.4 mA-hr. The over-all process can take place at a voltage of less than 1.5 volts and is therefore compatible with most commercial batteries.

The amount of gas generated by batteries such as the 357 silver oxide button cell is ca. 36 cc of oxygen, while the 675 Zinc-air battery can release from 110-140 cc of oxygen. Larger volumes can be produced from commercial alkaline batteries such as AAA and AA.

Since the rates of fluid deliveries of interest to this invention are generally less than 1 mL/day, the applied currents are less than 200 micro-amps. In fact, 20 micro-amps are adequate for delivery rates of 0.1 mL/day. Since air-operated electrochemical cells have a capacity of about 100 mA/cm<sup>2</sup>, or 550 cc of oxygen/day-cm<sup>2</sup>, it is apparent that to achieve the desired rates of 1 mL/day or less, the cell size can be extremely small, therefore, non-conventional electrochemical cell assemblies are required as compared to more conventional assemblies such as those described by Maget in U.S. Patent 6,010,317.

Figures 2A and 2B, in conjunction with Figures 3A and 3B, illustrate a slightly modified version of an autonomous electrochemical oxygen generator which, for oxygen generation, is controlled by an oxygen permeable film, either conductive 115 or non-conductive 125, thereby eliminating the need for the resistor 20 as required in the previously described electrochemical gas generator 10. This electrochemical gas generator 110 is somewhat similar to the previously described electrochemical gas generator 10 in that it has a container 111, with one or more oxygen inlets 114 on the bottom and an outlet 116 and activation member 118 on top of the container 111. The oxygen inlet 114 and bottom however has an upward extending recess 117 thereat adapted to receive a compression-type fitting 120, such as but not limited to washers, plugs, slugs, and lids, the purpose of which is

described later herein. A chamber 113 within the container 111 houses the battery holder 119 and the battery 12.

This electrochemical oxygen generator 110 is film-based and, unlike the previously described current-based electrochemical gas generator 10, is housed below the battery 12 and on the bottom of the container 111. In assembling this generator 110, a sealing ring 123 is placed on the floor [bottom] of the container 111, followed by the electrochemical cell assembly 30, and ending with the battery 12 in its holder 119.

In cases where the electrochemical cell assembly being used is that as illustrated in Figure 3A, construction is followed by placement of either a conductive oxygen-permeable film 115 or a non-conductive oxygen-permeable film 125 into the recess 117 followed by insertion of the compression-type fitting 120 into the recess and in contact with the conductive oxygen-permeable film 115 or a non-conductive oxygen-permeable film 125. Similar to the previously described generator 10, this is followed by crimping the container 111 inward and downward to achieve an electrical contact between the battery 12 and the electrochemical cell assembly 30 and the container 111.

With the compression-type fitting 120 so pressed into the recess 117 an intact and ready to use film-based electrochemical gas generator 110 is made. A ledge 122 supports the electrochemical cell assembly 30 and, with the sealing ring 123, maintains an air-tight integrity of this electrochemical gas generator 110.

As so configured a large cavity 47 is defined below the electrochemical cell assembly 30 and the floor of the container 111. A small cavity 37 is defined below the electrolytic membrane 31 and the lower segment of the oxygen-impermeable film 34. As will be

explained, the large cavity 47 serves an important function to the operation of this film-based electrochemical gas generator 110.

The compression-type fitting 120 should have one or more perforations 144 [one is shown] therein to permit access of air onto the oxygen-permeable film 115, 125. The oxygen-permeable film 115, 125 allows a certain amount of oxygen to diffuse across the oxygen-permeable film 115, 125 and to access the electrochemical cell assembly 30 above. A raised circular ridge 121 on the top of the compression-type fitting 120 defines the active area for oxygen permeation through the oxygen-permeable film 115, 125. The one or more perforations 144 are inside the circular ridge 121 and air for oxygen extraction contacts only the area of the oxygen-permeable film as defined by, and within, the circular ridge 121.

As previously described and illustrated in detail in Figure 3A, the upper and lower segments of the oxygen impermeable film 34 and the respective outward extensions 35 sandwich the membrane-electrode, current-collector combination 31, 32, and 33 and, with the outward extensions 35, prevents air from circulating around the electrochemical cell assembly 30 but forces oxygen to flow to the electrochemical cell assembly 30 to be processed, with oxygen being released at the discharge side 26 of the electrochemical cell assembly 30 and out of the electrochemical gas generator 110 through its outlet 116, and as a result, the oxygen generation rate is now controlled by oxygen transfer through this oxygen permeable film 115, 125 thereby eliminating the need for the resistor 20.

In cases where no compression-type fitting 120 is being applied, such as illustrated in Figures 4A and 4B [to be described in detail later] the film must be conductive oxygen-permeable 115 as illustrated by the electrochemical cell assembly 130 in Figure 3B. This

embodiment of Figures 4A and 4B simplifies the manufacture process and costs associated therewith.

In the embodiment illustrated in Figures 2A and 2B, the principle of operation of a film-based, or diffusion-based, oxygen generator eliminates the need for a resistor to control the current and thereby the oxygen generation. Conventionally-available and typical oxygen-permeable film 115, 125 should generally be of a silicone film and more specifically, if it is to be of the non-conductive type, a dimethylsilicone (DMS) film of known oxygen permeability such as produced by Silicone Products, Inc. It is the known permeability of the film which will dictate the quantity of oxygen to be generated and not the strength of the battery 12 rendering battery strength immaterial to its efficiency.

The rate of oxygen transfer through the above-mentioned DMS film 125 is  $60 \times 10^{-9}$  cc-cm/cm<sup>2</sup>-sec-cmHg pressure difference. If a specific oxygen partial pressure difference can be maintained across either type of oxygen-permeable film 115, 125, the oxygen transfer rate will be constant. If the partial pressure of oxygen on the down-stream side of the oxygen-permeable film 115, 125 is small (near zero) the oxygen pressure difference is set at about 16 cm of Hg. The transfer rate of oxygen then becomes equivalent to 0.083 cc-cm/day-cm<sup>2</sup>. For a film thickness of 10 mils, the rate becomes equivalent to 3.3 cc/day-cm<sup>2</sup>. To achieve a 1 cc/day transfer rate, the film diameter should generally be 0.6 cm.

To achieve the desired low oxygen pressure on the down-stream side of the oxygen-permeable film 115, 125, a battery voltage of 0.9 and 1.7 volts is applied directly to the electrochemical cell assembly 30, without current control.

Each of the film-based generators 110, 210 involve a two stage process for oxygen generation: [1] oxygen diffusion; and [2] electrochemical oxygen concentration.

With regard to the generator 110 illustrated in Figure 2A, oxygen within the large cavity 47, as defined by the boundaries of the oxygen-permeable film and the electrochemical cell assembly 30 will be immediately scavenged and released as pure oxygen at the cell assembly anode. In fact, applicant has obtained oxygen partial pressures in cavity as low as 100 ppm, or 0.008 cm Hg, a negligible value as compared to 16 cm Hg of oxygen pressure in air.

Figures 4A and 4B in conjunction with Figure 3B illustrates yet another embodiment of an electrochemical gas generator 210 also controlled by an oxygen-permeable film rather than a resistor 20 as previously described for the electrochemical gas generator 10. In this embodiment, however, the oxygen-permeable film must be electrically conductive 115. This electrochemical gas generator 210 is configured similarly to the previously described electrochemical gas generator 110 in that it has a container 211, with one or more inlets 214 on the bottom [one being illustrated for the purpose of allowing entry of an oxygen-containing gas, such as but not limited to, air] and an outlet 216 and activation member 218 on top of the container 211. A chamber 213 within the container 211 houses the battery holder 219 and the battery 12 securely positioned therein. A ledge 222 is defined on the bottom of the battery holder 219. The bottom, or floor, of the container 211 has a raised ridge 221 defining a perimeter thereon having a clearly defined inner side and an outer side. There is no need for the compression-type fitting 120 as in the electrochemical gas generator 110 as previously described.

In assembly of this embodiment, sealing ring 223 is first placed into the container 211 followed by the electrochemical cell assembly 130 [see Figure 3B], battery 12, and then the battery holder 219. Container 211 is then crimped inward and downward to achieve



electrical contact between the battery 12, electrochemical cell assembly 130, and the raised ridge 221. The ledge 222 in combination with the sealing ring 223 supports the electrochemical cell assembly 130 and maintains the required air-tight integrity necessary for the electrochemical gas generator 230 to properly and most efficiently function.

The one or more inlets 214 on the electrochemical gas generator 210 allows free access of any oxygen-containing gas, such as but not limited to, air to the electrochemical cell assembly 130 and the raised ridge 221, defining the active area [inner side of the perimeter] for air access to, and oxygen transfer across, the conductive oxygen-permeable film 115 to the electrolytic membrane 131 and lower electrode 132.

Figure 3B illustrates in detail the electrochemical cell assembly 130 used in the above described electrochemical gas generator 210. It is similar to the electrochemical cell assembly 30 previously described in that it has solid electrolytic membrane 131 onto which electrodes 132 are embedded on the top and on the bottom of the electrolytic membrane 131. A single current collector 133 is on top of the top electrode 132 and in intimate contact therewith to insure a low resistance electrical contact. A major difference with this electrochemical cell assembly 130 is that the lower current collector 33 as described for the electrochemical cell assembly 30 is replaced by the conductive oxygen-permeable film 115. Electrical conductivity is achieved by the addition of conductive materials to the film such as, but not limited to, carbon, graphite, silver, nickel, or other similarly conductive materials.

This membrane-electrode-film electrochemical cell assembly 130 is partially sandwiched between upper and lower segments of oxygen impermeable film 134 which is used to seal off the edges of electrochemical cell assembly 130 by way of outward extensions 135. As can be seen the oxygen impermeable film 134 sandwiches the membrane-electrode-

current collector-film combination 131, 132, 133, 115 and, with the outward extensions 135 in conjunction with the sealing ring 123 [refer to Figures 4A and 4B], prevents air from circulating around the electrochemical cell assembly 130 but forces the air to flow to the electrochemical cell assembly 130 from its air intake side 124, to be processed, with oxygen *being released at the discharge side 126 of the electrochemical cell assembly 130 and out of the electrochemical gas generator 210 through its outlet 216.*

Typical conventionally available components of the electrochemical cell assembly 130 include:

[1] for the electrolytic member (cation or anion) [131], a typical membrane which is manufactured by DuPont® and known as Nafion® ;

[2] for the electrodes [132], catalytically active materials such as platinum black or platinum activated carbons or graphite;

[3] for the current collector [133], which typically should be approximately 320 microns thick and less than 5mm in diameter, porous conductive carbons or graphite paper or porous conductive materials such as conductive silicone rubber or a metal screen;

[4] for the oxygen permeable film [115], a conductive silicon rubber produced by Silicone Products, Inc., of known oxygen permeability; and

[5] for the oxygen impermeable film [34] and outward extensions [35], DuPont's® commercially available Kapton® film.

This electrochemical gas generator 210 is activated by moving the activation member 218 in the direction of Arrow B which is then pressed and held in contact with the battery 12. After this movement is completed, the electrochemical cell assembly 130 immediately extracts oxygen from the small cavity 137. Since the oxygen-permeable film 115 is in intimate contact with the lower electrode 132, and because the cavity 137 is extremely small, oxygen pressure in the small cavity 137 is instantly decreased to near zero. This difference in oxygen pressure as contrasted to the air pressure on the intake side 124 of the electrochemical cell assembly 130 becomes the driving force for oxygen transfer across the oxygen-permeable film 115 and subsequent release from the upper electrode [anode] and discharge from the electrochemical gas generator 210 from its outlet 216.

The present disclosure includes that contained in the present claims as well as that of the foregoing description. Although this electrochemical gas generator and cell assemblies have been described in its preferred forms with a certain degree of particularity, it is understood that the present disclosure of the preferred forms has been made only by way of example and numerous changes in the details of construction and combination and arrangement of parts and method steps may be resorted to without departing from the spirit

and scope of the electrochemical gas generator and cell assemblies. Accordingly, the scope of the electrochemical gas generator and cell assemblies should be determined not by the embodiment[s] illustrated, but by the appended claims and their legal equivalents.

It must be understood, however, that there may be unforeseeable insubstantial modifications to electrochemical gas generator and cell assemblies that remain as equivalents and thereby falling within the scope of the electrochemical gas generator and cell assemblies described and claimed herein.

CLAIMS

What is claimed is:

1. An electrochemical gas generator comprising:

(a) a container having a chamber within, a top with one or more outlets therein, and a bottom with one or more inlets therein;

(b) a battery within said chamber;

(c) an electrochemical cell assembly above, and in communication with, said battery, said electrochemical cell assembly comprising an electrolytic membrane, a catalytically active electrode above and below said electrolytic membrane, a conductive and porous current collector above and below each of said electrodes, and an upper and a lower oxygen-impermeable film, each with an outward extension in sealing communication with one another, said upper and lower oxygen-impermeable film above and below and encircling and pressing onto each one of said current collectors thereby forming an air-tight seal therearound;

(d) a conductive member in between said battery and said electrochemical cell assembly and in direct communication with said battery and said electrochemical cell assembly;

(e) activation means for activating said electrochemical gas generator; and

(f) current controller means for controlling electric current, said current controller means in communication with said battery and said activation means.

2. The electrochemical gas generator of Claim 1 wherein said electrolytic membrane is of the cation or anion type.
3. The electrochemical gas generator of Claim 1 wherein said current controller means comprises a resistor.
4. An electrochemical gas generator comprising:
  - (a) a container having a chamber within, a top with one or more outlets therein, and a bottom with an upward extending recess and one or more gas inlets on said bottom;
  - (b) a battery within said chamber;
  - (c) an electrochemical cell assembly below, and in communication with, said battery, said electrochemical cell assembly comprising an electrolytic membrane, a catalytically active electrode above and below said electrolytic membrane, a conductive and porous current collector above and below each of said electrodes, and an upper and a lower oxygen-impermeable film, each with an outward extension in sealing communication with one another, said upper and lower oxygen-impermeable film above and below and encircling and pressing onto each one of said current collectors thereby forming an air-tight seal therearound;
  - (d) activation means for activating said electrochemical gas generator;
  - (e) an oxygen-permeable film of a pre-determined oxygen permeability in said recess;and

(f) compression means for pressing said oxygen-permeable film into a direct communication with said bottom of said container, said compression means having one or more inlets therein.

5. The electrochemical gas generator of Claim 4 wherein said electrolytic membrane is of the cation or anion type.

6. The electrochemical gas generator of Claim 4 wherein said compression means is selected from the group consisting of washers, plugs, slugs, and lids.

7. The electrochemical gas generator of Claim 4 wherein said oxygen-permeable film is of the conductive or non-conductive type.

8. The electrochemical gas generator of Claim 4 further comprising active area means for generating and releasing gases, said active area means encircling said one or more inlets and wherein said one or more gas inlets are above and in communication with generated and released gases.

9. The electrochemical gas generator of Claim 8 wherein said active area means comprises an upward projecting ridge.

10. An electrochemical gas generator comprising:

(a) a container having a chamber within, a top with one or more outlets therein, and a bottom with an upward extending recess and one or more inlets on said bottom;

(b) a battery within said chamber;

(c) an electrochemical cell assembly below, and in communication with, said battery, said electrochemical cell assembly comprising an electrolytic membrane, a catalytically active upper electrode above said electrolytic membrane, a catalytically active lower electrode below said electrolytic membrane, a conductive and porous current collector above said upper electrode, an oxygen-permeable film of the conductive type and of a pre-determined oxygen permeability below said lower electrode, and an upper and a lower oxygen-impermeable film, each with an outward extension in sealing communication with one another, wherein said upper oxygen-impermeable is above and encircling and pressing onto said current collector and said lower oxygen-impermeable film is below and encircling and pressing onto said oxygen-permeable film thereby forming an air-tight seal therearound; and

(d) activation means for activating said electrochemical gas generator.

11. The electrochemical gas generator of Claim 10 wherein said electrolytic membrane is of the cation or anion type.

12. The electrochemical gas generator of Claim 10 further comprising active area means for generating and releasing gases, said active area means on said bottom and encircling said one or more inlets and wherein said one or more gas inlets are above and in communication with generated and released gases.



13. The electrochemical gas generator of Claim 12 wherein said active area means comprises an upward projecting ridge.

14. An electrochemical cell assembly comprising:

an electrolytic membrane;

a catalytically active electrode above and below said electrolytic membrane;

a conductive and porous current collector above and below each of said electrodes;

and

an upper and a lower oxygen-impermeable film, each with an outward extension in sealing communication with one another, said upper and lower oxygen-impermeable film above and below and encircling and pressing onto each one of said current collectors thereby forming an air-tight seal therearound.

15. The electrochemical cell assembly of Claim 14 wherein said electrolytic membrane is of the cation or anion type.

16. The electrochemical cell assembly of Claim 14 wherein said oxygen-permeable film is of the conductive or non-conductive type.

17. An electrochemical cell assembly comprising:

an electrolytic membrane;

a catalytically active upper electrode above said electrolytic membrane;

a catalytically active lower electrode below said electrolytic membrane;

a conductive and porous current collector above said upper electrode;

an oxygen-permeable film of the conductive type and of a pre-determined oxygen permeability below said lower electrode; and

an upper and a lower oxygen-impermeable film, each with an outward extension in sealing communication with one another, wherein said upper oxygen-impermeable is above and encircling and pressing onto said current collector and said lower oxygen-impermeable film is below and encircling and pressing onto said oxygen-permeable film thereby forming an air-tight seal therearound.

18. The electrochemical cell assembly of Claim 17 wherein said electrolytic membrane is of the cation or anion type.

AMENDED CLAIMS  
received by the International Bureau on 26 July 2010

1. An electrochemical gas generator comprising:

(a) a container having a chamber within, a top with one or more outlets therein, and a bottom with one or more inlets therein;

(b) a battery within said chamber;

(c) an electrochemical cell assembly, within said chamber, located above, and in communication with, said battery, said electrochemical cell assembly comprising an electrolytic membrane, a catalytically active electrode above and below said electrolytic membrane, a conductive and porous current collector above and below each of said electrodes, and an upper and a lower oxygen-impermeable film, each with an outward extension in sealing communication with one another, said upper and lower oxygen-impermeable film above and below and encircling and pressing onto each one of said current collectors thereby forming an air-tight seal therearound, at least one of said upper and lower oxygen-impermeable films forming an airtight seal at a location intermediate said current collector air-tight seal and said outward extension seal;

(d) a conductive member in between said battery and said electrochemical cell assembly and in direct communication with said battery and said electrochemical cell assembly;

(e) activation means for activating said electrochemical gas generator; and

(f) current controller means for controlling electric current, said current controller means in communication with said battery and said activation means.

2. The electrochemical gas generator of Claim 1 wherein said electrolytic membrane is of the cation or anion type.

AMENDED SHEET (ARTICLE 19)

3. The electrochemical gas generator of Claim 1 wherein said current controller means comprises a resistor.

4. An electrochemical gas generator comprising:

(a) a container having a chamber within, a top with one or more outlets therein, and a bottom with an upward extending recess and one or more gas inlets on said bottom;

(b) a battery within said chamber;

(c) an electrochemical cell assembly, within said chamber, located below, and in communication with, said battery, said electrochemical cell assembly comprising an electrolytic membrane, a pair of catalytically active electrodes, one said electrode above and one said electrode below said electrolytic membrane, a conductive and porous current collector above and below each of said electrodes, and an upper and a lower oxygen-impermeable film, each with an outward extension in sealing communication with one another, said upper and lower oxygen-impermeable film above and below and encircling and pressing onto each one of said current collectors thereby forming an air-tight seal therearound, at least one of said upper and lower oxygen-impermeable films forming an airtight seal at a location intermediate said current collector air-tight seal and said outward extension seal;

(d) activation means for activating said electrochemical gas generator;

(e) an oxygen-permeable film of a pre-determined oxygen permeability in said recess;

and

(f) compression means for pressing said oxygen-permeable film into a direct communication with said bottom of said container, said compression means having one or more inlets therein.

AMENDED SHEET (ARTICLE 19)

5. The electrochemical gas generator of Claim 4 wherein said electrolytic membrane is of the cation or anion type.
6. The electrochemical gas generator of Claim 4 wherein said compression means is selected from the group consisting of washers, plugs, slugs, and lids.
7. The electrochemical gas generator of Claim 4 wherein said oxygen-permeable film is of the conductive or non-conductive type.
8. The electrochemical gas generator of Claim 4 further comprising active area means for generating and releasing gases, said active area means encircling said one or more inlets and wherein said one or more gas inlets are above and in communication with generated and released gases.
9. The electrochemical gas generator of Claim 8 wherein said active area means comprises an upward projecting ridge.
10. An electrochemical gas generator comprising:
  - (a) a container having a chamber within, a top with one or more outlets therein, and a bottom with an upward extending recess and one or more inlets on said bottom;
  - (b) a battery within said chamber;
  - (c) an electrochemical cell assembly, within said chamber, located below, and in communication with, said battery, said electrochemical cell assembly comprising an electrolytic membrane, a catalytically active upper electrode above said electrolytic membrane, a catalytically active lower electrode below said electrolytic membrane, a conductive and porous

current collector above said upper electrode, an oxygen-permeable film of the conductive type and of a pre-determined oxygen permeability below said lower electrode, and an upper and a lower oxygen-impermeable film, each with an outward extension in sealing communication with one another, wherein said upper oxygen-impermeable film is above and encircling and pressing onto said current collector and said lower oxygen-impermeable film is below and encircling and pressing onto said oxygen-permeable film thereby forming an air-tight seal therearound, at least one of said upper and lower oxygen-impermeable films forming an airtight seal at a location intermediate said current collector air-tight seal and said outward extension seal; and

(d) activation means for activating said electrochemical gas generator.

11. The electrochemical gas generator of Claim 10 wherein said electrolytic membrane is of the cation or anion type.

12. The electrochemical gas generator of Claim 10 further comprising active area means for generating and releasing gases, said active area means on said bottom and encircling said one or more inlets and wherein said one or more gas inlets are above and in communication with generated and released gases.

13. The electrochemical gas generator of Claim 12 wherein said active area means comprises an upward projecting ridge.

14. An electrochemical cell assembly comprising:

an electrolytic membrane defined by an upper surface and a lower surface;

a one catalytically active electrode above and one said electrode below said electrolytic membrane;

a conductive and porous current collector above and below each of said electrodes; and  
an upper oxygen-impermeable film and a lower oxygen-impermeable film, each with an outward extension forming an air-tight seal with the other said film, said upper and lower oxygen-impermeable film above and below and encircling and pressing onto each one of said current collectors thereby forming an air-tight seal therearound, and at least one of:

said upper oxygen-impermeable film forming an air-tight seal with said membrane upper surface at a location intermediate to said outward extension seal and said current collector seal, and

said lower oxygen-impermeable film forming an air-tight seal with said membrane lower surface at a location intermediate to said outward extension seal and said current collector seal.

15. The electrochemical cell assembly of Claim 14 wherein said electrolytic membrane is of the cation or anion type.

17. An electrochemical cell assembly comprising:

an electrolytic membrane;

a catalytically active upper electrode above said electrolytic membrane;

a catalytically active lower electrode below said electrolytic membrane;

a conductive and porous current collector above said upper electrode;

an oxygen-permeable film of the conductive type and of a pre-determined oxygen permeability below said lower electrode; and

an upper and a lower oxygen-impermeable film, each with an outward extension in sealing communication with one another, wherein said upper oxygen-impermeable film is above and encircling and pressing onto said current collector and said lower oxygen-impermeable film

AMENDED SHEET (ARTICLE 19)

is below and encircling and pressing onto said oxygen-permeable film thereby forming an airtight seal therearound, and wherein at least one of:

(a) said upper oxygen-impermeable film is further defined by an airtight seal to said membrane intermediate said outward extension seal and where said upper oxygen-impermeable film is pressing onto said current collector, and

(b) said lower oxygen-impermeable film is further defined by an airtight seal to said membrane intermediate said outward extension and where said lower oxygen-impermeable film is pressing onto said oxygen-permeable film.

18. The electrochemical cell assembly of Claim 17 wherein said electrolytic membrane is of the cation or anion type.

AMENDED SHEET (ARTICLE 19)



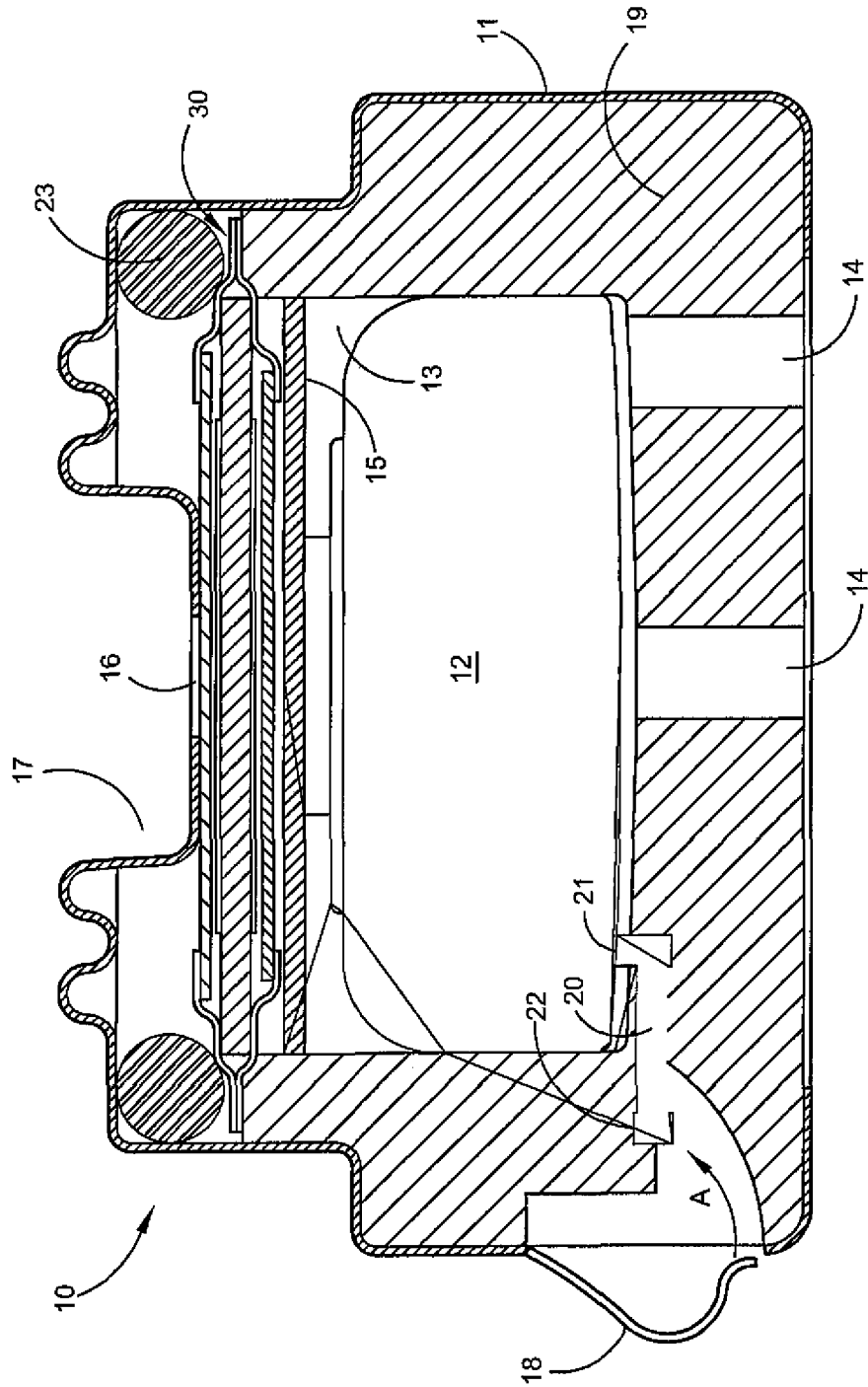
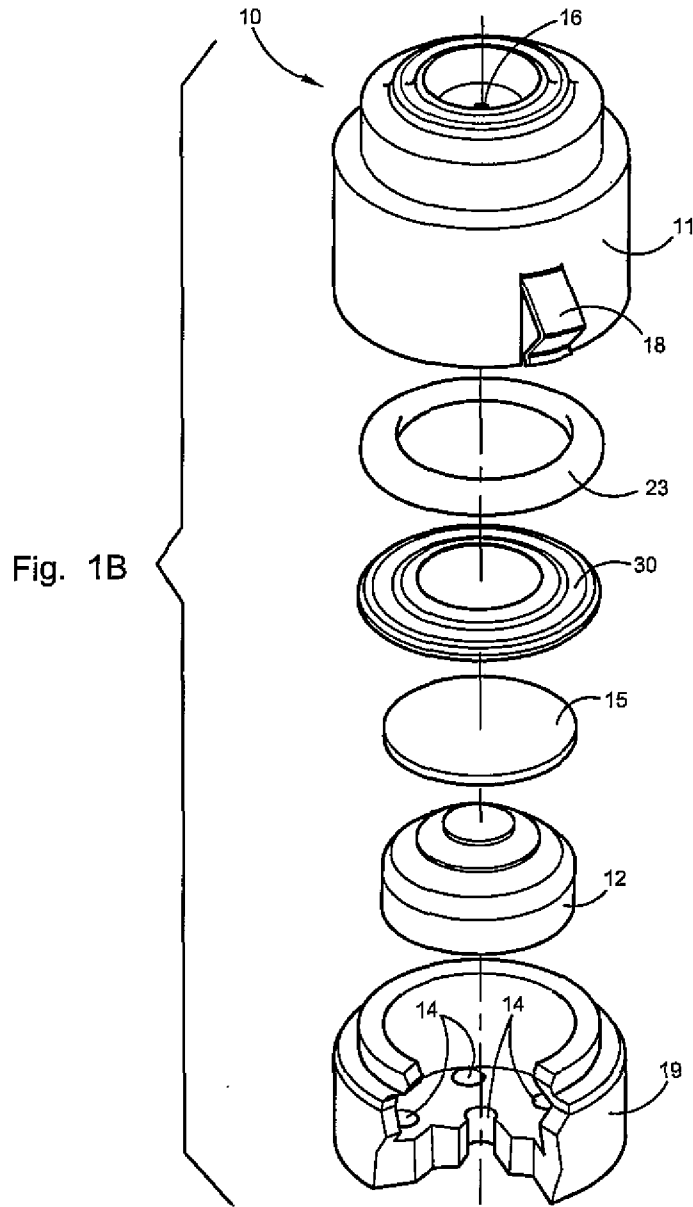

Fig. 1A



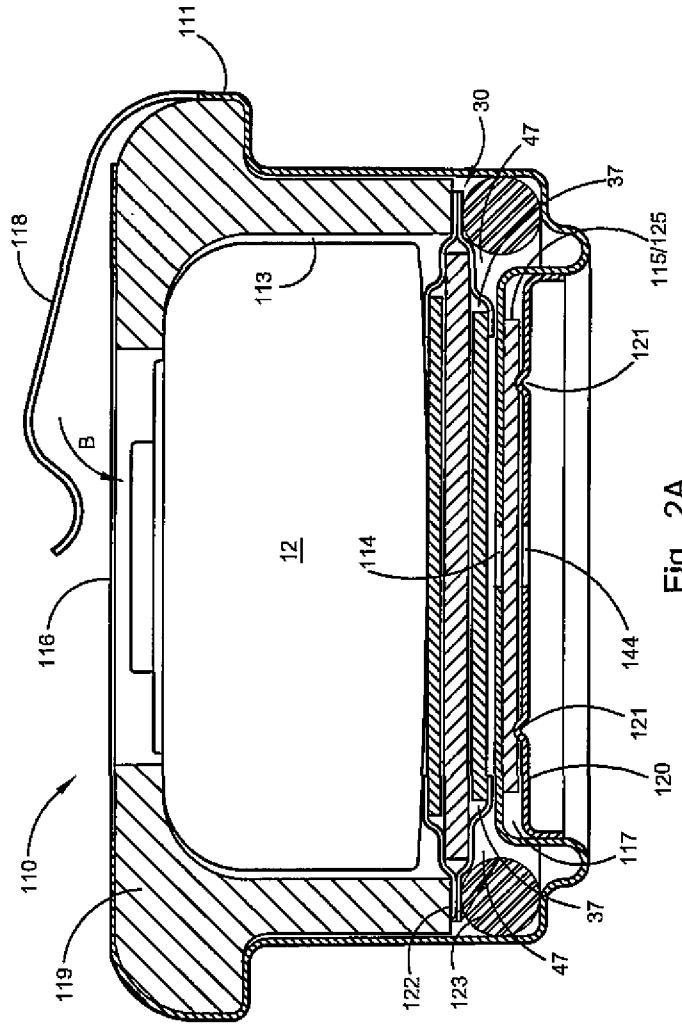
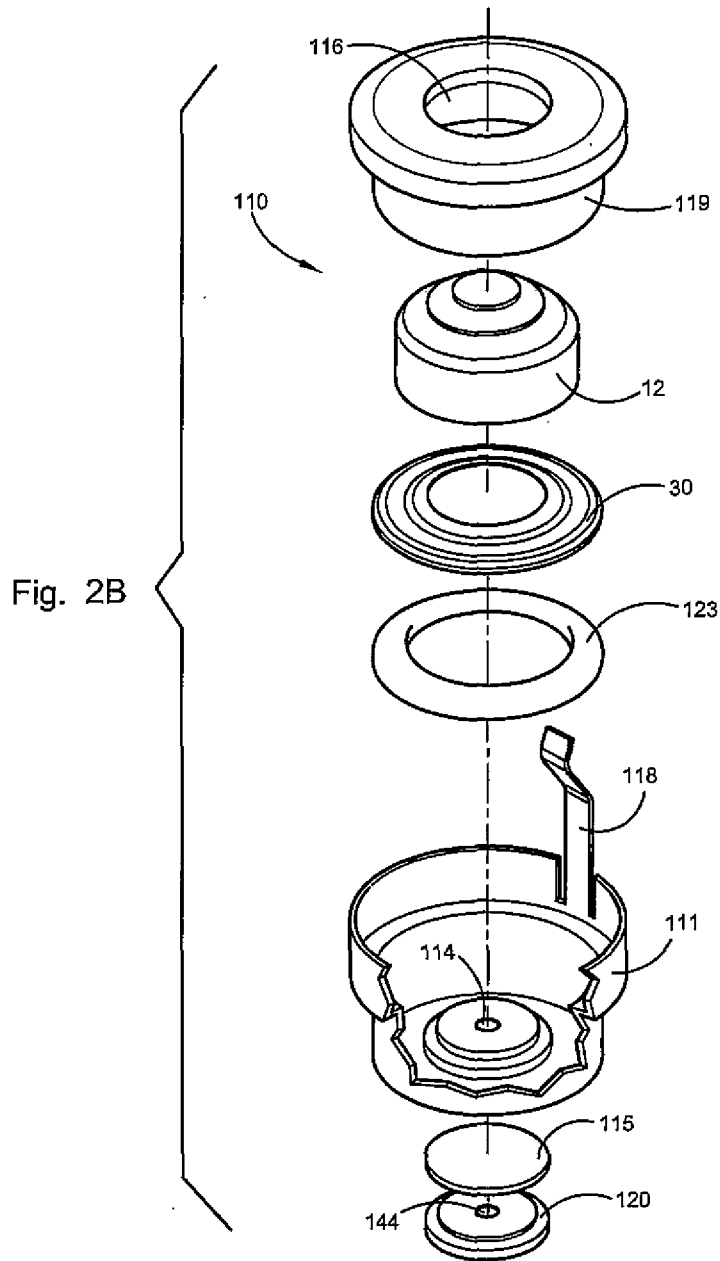

Fig. 2A

4/7



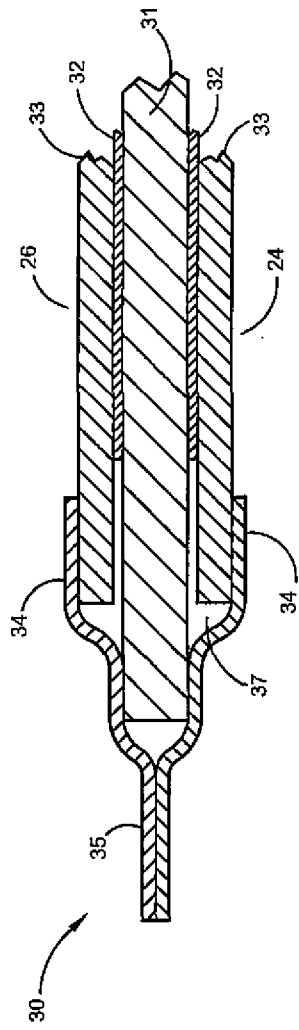

Fig. 3A

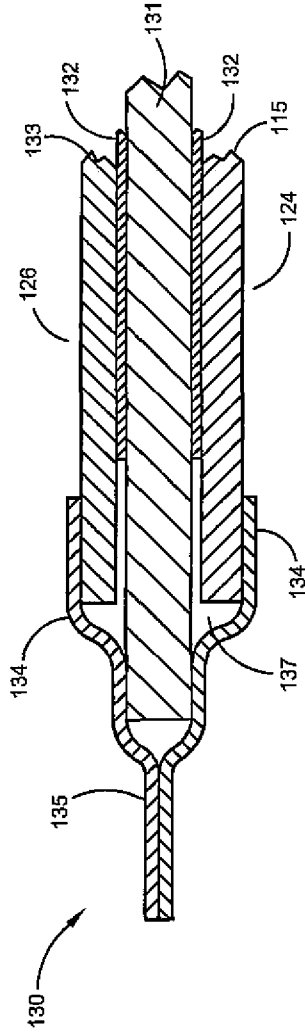

Fig. 3B

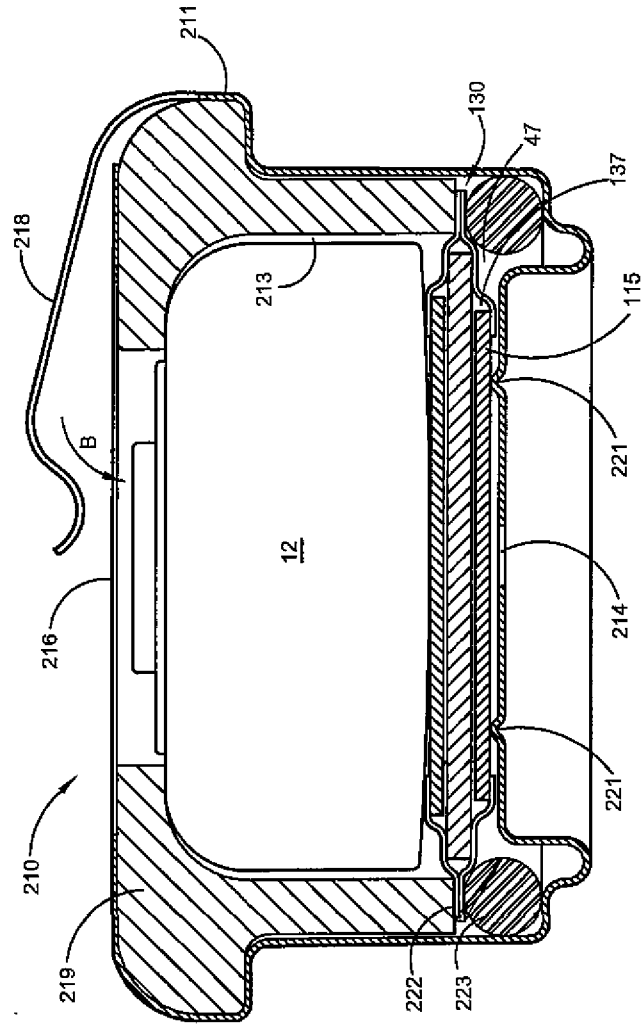
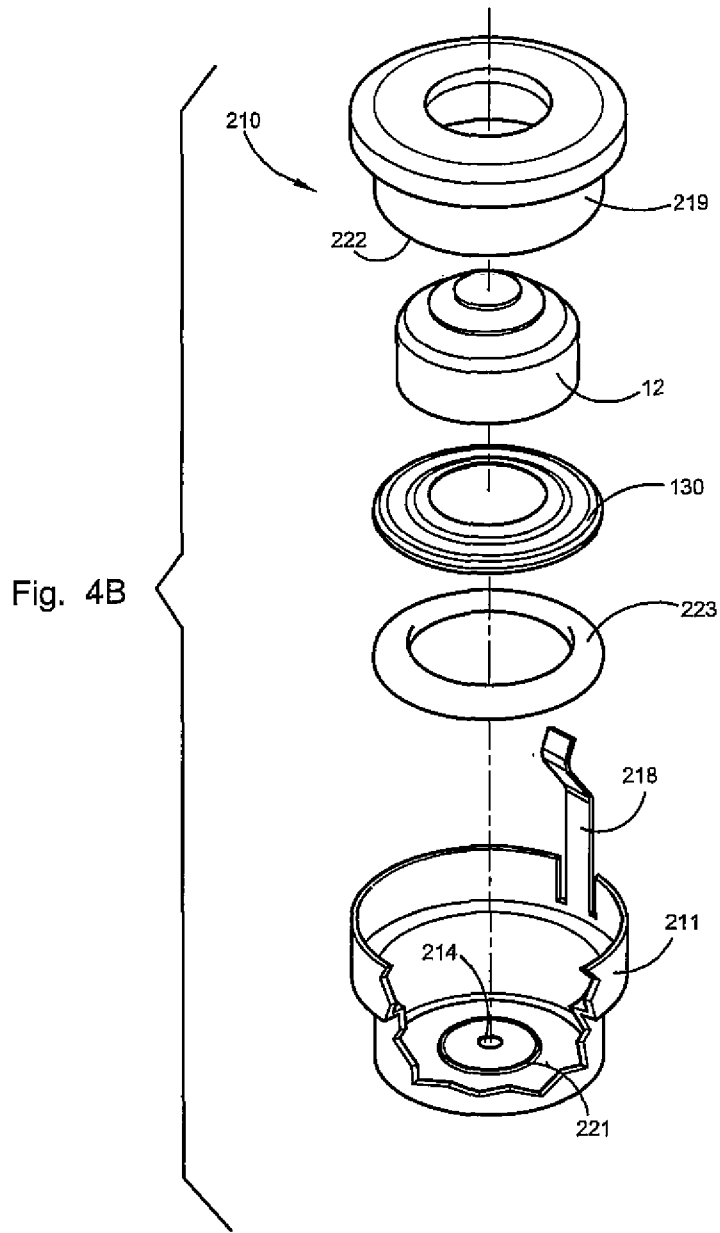

Fig. 4A

7/7



# INTERNATIONAL SEARCH REPORT

International application No  
PCT/US2010/025852

<b>A. CLASSIFICATION OF SUBJECT MATTER</b> INV. C25B9/10      A01M1/20      A61L9/12      A61M5/142      F16N13/00 ADD.		
According to International Patent Classification (IPC) or to both national classification and IPC		
<b>B. FIELDS SEARCHED</b> Minimum documentation searched (classification system followed by classification symbols) C25B A01M A61L A61M F16N		
Documentation searched other than minimum documentation to the extent that such documents are included in the fields searched		
Electronic data base consulted during the international search (name of data base and, where practical, search terms used) EPO-Internal, WPI Data		
<b>C. DOCUMENTS CONSIDERED TO BE RELEVANT</b>		
Category*	Citation of document, with indication, where appropriate, of the relevant passages	Relevant to claim No.
X	US 4 902 278 A (MAGET HENRI J R [US] ET AL) 20 February 1990 (1990-02-20) claims 1-6, 11, 19-21 column 2, lines 12-21, 27-46, 51-64 column 3, lines 54-67 column 4, lines 30-48 column 6, lines 1-12 column 8, line 8 - line 54 column 10, line 40 - line 61  <div style="text-align: center;">----- -/--</div>	1-18
<input checked="" type="checkbox"/> Further documents are listed in the continuation of Box C. <input checked="" type="checkbox"/> See patent family annex.		
* Special categories of cited documents :		
"A" document defining the general state of the art which is not considered to be of particular relevance "E" earlier document but published on or after the international filing date "L" document which may throw doubts on priority claim(s) or which is cited to establish the publication date of another citation or other special reason (as specified) "O" document referring to an oral disclosure, use, exhibition or other means "P" document published prior to the international filing date but later than the priority date claimed	"T" later document published after the international filing date or priority date and not in conflict with the application but cited to understand the principle or theory underlying the invention "X" document of particular relevance; the claimed invention cannot be considered novel or cannot be considered to involve an inventive step when the document is taken alone "Y" document of particular relevance; the claimed invention cannot be considered to involve an inventive step when the document is combined with one or more other such documents, such combination being obvious to a person skilled in the art. "&" document member of the same patent family	
Date of the actual completion of the international search  <div style="text-align: center;">12 May 2010</div>	Date of mailing of the international search report  <div style="text-align: center;">26/05/2010</div>	
Name and mailing address of the ISA/ European Patent Office, P.B. 5818 Patentlaan 2 NL - 2280 HV Rijswijk Tel. (+31-70) 340-2040, Fax: (+31-70) 340-3016	Authorized officer  <div style="text-align: center;">Perednis, Dainius</div>	



## INTERNATIONAL SEARCH REPORT

International application No

PCT/US2010/025852

C(Continuation). DOCUMENTS CONSIDERED TO BE RELEVANT		
Category*	Citation of document, with indication, where appropriate, of the relevant passages	Relevant to claim No.
X Y	US 6 010 317 A (MAGET HENRI J R [US] ET AL) 4 January 2000 (2000-01-04) claims 1,4,5,8-10,14 column 1, line 57 - column 2, line 2 column 2, line 43 - line 58 column 3, line 31 - line 48 column 5, paragraphs 3, 5 column 6, lines 1-7, 63-67 column 7, lines 1-5, 33-64	1-3, 14-16 4-13,17, 18
X Y	US 5 928 194 A (MAGET HENRI J R [US]) 27 July 1999 (1999-07-27) claims 1,17,21, 31 column 10, line 63 - column 11, line 13 column 11, line 44 - line 46 column 11, line 57 - column 12, line 13 column 12, line 39 - line 51	1-3, 14-16 4-13,17, 18
X Y	US 5 681 435 A (JOSHI ASHOK V [US] ET AL) 28 October 1997 (1997-10-28) claims 1, 4 column 1, paragraph 4 column 6, paragraphs 4, 6 column 7, lines 7-10, 42-62 column 8, line 28 - line 38 column 9, line 14 - line 18	1-3, 14-16 4-13,17, 18

# INTERNATIONAL SEARCH REPORT

Information on patent family members

International application No PCT/US2010/025852
---

Patent document cited in search report	A	Publication date	Patent family member(s)	Publication date
US 4902278	A	20-02-1990	NONE	
US 6010317	A	04-01-2000	AU 762290 B2	19-06-2003
			AU 5777199 A	21-03-2000
			BR 9906779 A	26-09-2000
			CA 2306231 A1	09-03-2000
			DE 69921604 D1	09-12-2004
			DE 69921604 T2	27-10-2005
			EP 1027087 A1	16-08-2000
			ES 2233075 T3	01-06-2005
			JP 2002523627 T	30-07-2002
			JP 2009215654 A	24-09-2009
			NZ 504105 A	25-10-2002
			WO 0012159 A1	09-03-2000
US 5928194	A	27-07-1999	NONE	
US 5681435	A	28-10-1997	US 5454922 A	03-10-1995